

## Kesse cookingAGENT, šedá



### Parametry

<b>Barva</b>	Šedá
<b>Značka</b>	Kesseböhmer (Kesseboehmer)
<b>Šířka skříňky</b>	300 mm
<b>Mechanismus</b>	Tlumení
<b>Typ výsuvů</b>	Skryté výsuvy
<b>Typ košů</b>	Organizéry
<b>Nosnost</b>	16 kg
<b>Označení produktu výrobcem</b>	025235 0102
<b>Minimální objednáací množství</b>	10

### Popis produktu

Kesse CookingAGENT The Kesse cookingAGENT is a versatile full-extension pull-out system that transforms your kitchen organization. By bringing all stored contents to the front, it provides unmatched convenience and accessibility. This innovative base unit pull-out is not only ideal for storing cooking essentials but also serves as a compact food storage solution. Designed for bottom mounting, it features carry baskets with non-slip rubber feet, ensuring stability. All plastic components are removable, dishwasher-proof, and resistant to common household cleaning materials, offering effortless maintenance. Key Features: Full-extension pull-out system for enhanced convenience and accessibility. Can function as a cooking essentials organizer or compact food storage unit. Bottom-mounted design with carry baskets featuring non-slip rubber feet. Removable, dishwasher-proof plastic components for easy cleaning. Resistant to all commonly used household cleaning materials. Manufactured by Kesseböhmer for superior quality and durability.



Instalační instrukce (manuál)

## cookingAGENT



**KESSEBÖHMER**  
CLEVER STORAGE



<http://support.kesseboehmer.de/cookingagent>

### Montageanleitung

Innenauszug - Bodenmontiert -  
Höhe 618 mm - cookingAGENT

### Mounting Instructions

Pull-out for hinged door - bottom  
assembly - Height 618 mm  
cookingAGENT

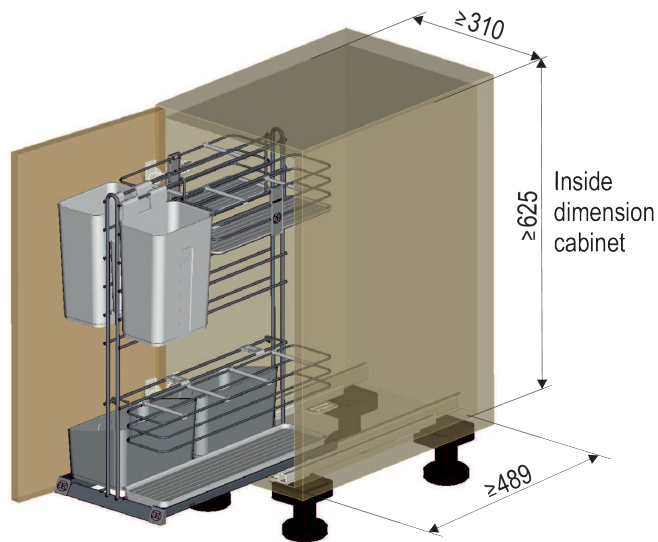
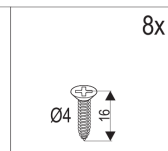
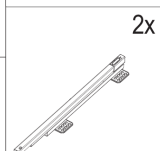
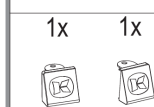
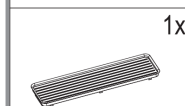
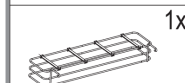
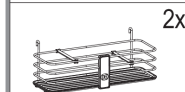
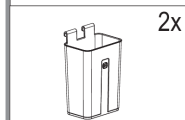
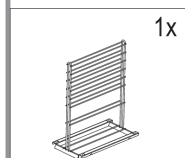

= max 16 kg

Beladung  
Load

KESSEBÖHMER MA 402598 0000 Rev.: 005-2020-08-31



2 3 4

## cookingAGENT



Symbole • Symbols • Symboles • Simboli • Símbolos • Símbolos • Merkit • Symboler • Symboly • Symbole  
Символы • Semboller • Σύμβολα • 記号 • 标志

	<p><b>DE</b> Warnung! <b>IT</b> Avvertenza! <b>FR</b> Variétés! <b>PL</b> Ostrzeżenie! <b>TR</b> Uyarı! <b>JP</b> 警告</p>	<p><b>UK</b> Warning! <b>ES</b> Advertencia! <b>DK</b> Advarsel! <b>RU</b> Внимание! <b>GR</b> Προσοχή!</p>	<p><b>FR</b> Avertissement! <b>PT</b> Aviso! <b>CZ</b> Výstraha!</p>
	<p><b>DE</b> Nicht korrekt! <b>IT</b> Non corretto! <b>FR</b> Vââm! <b>PL</b> Nieprawidłowo! <b>TR</b> Doğru değil! <b>JP</b> 正しくありません</p>	<p><b>UK</b> Incorrect! <b>ES</b> ¡Incorrecto! <b>DK</b> Ikke korrekt! <b>RU</b> Неправильно! <b>GR</b> Οχι σωστό!</p>	<p><b>FR</b> Incorrect! <b>PT</b> Incorreto! <b>CZ</b> Nesprávně!</p>
	<p><b>DE</b> Korrekt! <b>IT</b> Corretto! <b>FR</b> Oikein! <b>PL</b> Prawidłowo! <b>TR</b> Doğru! <b>JP</b> 正しいです</p>	<p><b>UK</b> Correct! <b>ES</b> ¡Correcto! <b>DK</b> Korrekt! <b>RU</b> Правильно! <b>GR</b> Σωστό!</p>	<p><b>FR</b> Correct! <b>PT</b> Correcto! <b>CZ</b> Správně!</p>
	<p><b>DE</b> Fixieren/fixiert! <b>IT</b> Fissare/fissato! <b>FR</b> Kinnittää/kinnitetty! <b>PL</b> Zamocować/zamocowane! <b>TR</b> Sabitleme/sabit! <b>JP</b> 固定する</p>	<p><b>UK</b> Secure/Secured! <b>ES</b> ¡Fijar/fijado! <b>DK</b> Spænde/spændt! <b>RU</b> Заблокировать / заблокирован! <b>GR</b> Στερεώση/στερεωμένο!</p>	<p><b>FR</b> Fixer/fixé! <b>PT</b> Fixar/fixo! <b>CZ</b> Upevnit/upevněno!</p>
	<p><b>DE</b> Lösen/gelöst! <b>IT</b> Allentare/allentato! <b>FR</b> Irrota/irrotettu! <b>PL</b> Zwolnić/zwolnione! <b>TR</b> Çıkarma/çıkık! <b>JP</b> はずす</p>	<p><b>UK</b> Release/Released! <b>ES</b> ¡Soltar/suelto! <b>DK</b> Løsne/løst! <b>RU</b> Разблокировать / разблокирован! <b>GR</b> Αποσυμπίεση!</p>	<p><b>FR</b> Détacher/détaché <b>PT</b> Soltar/solto! <b>CZ</b> Povolit/povoleno!</p>
	<p><b>DE</b> Keinen Akkuschrauber verwenden! <b>IT</b> Non utilizzare un avvitatore a batteria! <b>FR</b> Não usar aparafusadora sem fio! <b>PL</b> Nie używać akumulatorowej! <b>TR</b> Akülü vidalama makinesini kullanmayın! <b>JP</b> コードレススクリュードライバーを使用しないでください。</p>	<p><b>UK</b> Do not use a cordless screwdriver! <b>ES</b> No utilizar taladro atomillador! <b>DK</b> Brug ikke batteriskruetrækker! <b>RU</b> Не использовать шуруповёрт с аккумуляторным питанием! <b>GR</b> Μη χρησιμοποιείτε σταθμοσφρίτζενο καταβίδι!</p>	<p><b>FR</b> Ne pas utiliser de tournevis à piles <b>PT</b> Não usar aparafusadora sem fio! <b>CZ</b> Neopoužívejte akušroubovák!</p>
	<p><b>DE</b> P2Z-Schraubendreher verwenden! <b>IT</b> Usare il cacciavite P2Z! <b>FR</b> Käytä P2Z-ruuvitalitait! <b>PL</b> Użyć wkrętaka P2Z! <b>TR</b> P2Z-Tornavidası kullanın! <b>JP</b> 手動のスクリュードライバー使用してください。</p>	<p><b>UK</b> Use a P2Z screwdriver! <b>ES</b> ¡Utilizar un destornillador P2Z! <b>DK</b> Brug P2Z-skrueftrækker! <b>RU</b> Использовать отвертку P2Z! <b>GR</b> Χρησιμοποιείτε καταβίδι P2Z!</p>	<p><b>FR</b> Utiliser un tournevis P2Z <b>PT</b> Usar chave de parafusos P2Z! <b>CZ</b> Použíte klíčový šroubovák P2Z!</p>
	<p><b>DE</b> Optionales Element! <b>IT</b> Elemento opzionale! <b>FR</b> Valinnainen elementti! <b>PL</b> Element opcjonalny! <b>TR</b> Seçenekli eleman! <b>JP</b> 取付可能なエレメントです。</p>	<p><b>UK</b> Optional element! <b>ES</b> Elemento opcional! <b>DK</b> Valgfrit element! <b>RU</b> Необязательный элемент! <b>GR</b> Προαιρετικό στοιχείο!</p>	<p><b>FR</b> Élément optionnel! <b>PT</b> Elemento opcional! <b>CZ</b> Volitelný prvek!</p>
	<p><b>DE</b> Klick-Geräusch beim Einrasten! <b>IT</b> Quando si innesta si sente un clic! <b>FR</b> Luultuessa kuuluu klik-ääni! <b>PL</b> Trzask przy zaskakowaniu! <b>TR</b> Birbirine geçişinde tk sesi oluşur! <b>JP</b> はめるときにカチャッという音を確認してください。</p>	<p><b>UK</b> Audible click on engagement! <b>ES</b> Cuando encaja se oye un clic! <b>DK</b> Kliklyd ved monteringen! <b>RU</b> Щелчок при фиксации! <b>GR</b> No ακουστεί κλικ κατά την εισρόφιση!</p>	<p><b>FR</b> «Clic» lors de l'encliquetage <b>PT</b> Ruído de clique ao engatar! <b>CZ</b> Systětné zazvuknutí!</p>
	<p><b>DE</b> Alle Maße in mm! <b>IT</b> Tutte le dimensioni in mm! <b>FR</b> Kaikki mitat mm! <b>PL</b> Wszystkie wymiary w mm! <b>TR</b> Tüm ebatlar mm bazında! <b>JP</b> すべての単位は ミリメートルです。</p>	<p><b>UK</b> All dimensions in mm! <b>ES</b> Todas las medidas son en mm! <b>DK</b> Alle mål er mm! <b>RU</b> Все размеры в мм! <b>GR</b> Όλες οι διαστάσεις σε mm!</p>	<p><b>FR</b> Toutes les dimensions en mm! <b>PT</b> Todas as medidas em mm! <b>CZ</b> Všechny rozměry v mm!</p>
	<p><b>DE</b> Ausziehsicherung vorhanden! <b>IT</b> Sicura di estrazione presente! <b>FR</b> Varusteiden ulosveto-osaystäm <b>PL</b> Zamontowano zabezpieczenie przed wyciągnięciem! <b>TR</b> Çekme emniyeti mevcuttur! <b>JP</b> 引き出し保護があります。</p>	<p><b>UK</b> Pull-out stop available! <b>ES</b> Torre de seguridad integrada! <b>DK</b> Med udtræksstop! <b>RU</b> Имеется ограничитель выдвижения! <b>GR</b> Με ασφαλιστικό σύστημα μίχθωνοσύου!</p>	<p><b>FR</b> Présence d'une protection anti-sortie ! <b>PT</b> Protecção contra extração disponível! <b>CZ</b> Namontovaná pojistka proti vytažení!</p>
	<p><b>DE</b> Korrosionsprüfung nach DIN EN ISO 6270-2 <b>IT</b> Prova di corrosione secondo la norma DIN EN ISO 6270-2 <b>FR</b> DIN EN ISO 6270-2 muk korroosioasteaus <b>PL</b> Badanie odporności na korozję wg DIN EN ISO 6270-2 <b>TR</b> DIN EN ISO 6270-2ye uygun Korozyon denetimi <b>JP</b> DIN EN ISO 6270-2準拠の腐食検査</p>	<p><b>UK</b> Corrosion test according to DIN EN ISO 6270-2 <b>ES</b> Prueba de corrosión según DIN EN ISO 6270-2 <b>DK</b> Korrosionsprøving iht. DIN EN ISO 6270-2 <b>RU</b> Испытание на коррозионную стойкость согласно DIN EN ISO 6270-2 <b>GR</b> Δοκιμή διάβρωσης κατά DIN EN ISO 6270-2</p>	<p><b>FR</b> Contrôle de la corrosion selon DIN EN ISO 6270-2 <b>PT</b> Ensaio de corrosão conforme DIN EN ISO 6270-2 <b>CZ</b> Korozní zkouška dle DIN EN ISO 6270-2</p>

**DE** Die technischen Darstellungen und Maßangaben – auch bei Abbildungen und Zeichnungen – sind unverbindlich. Konstruktionsverbesserungen sind vorbehalten! **UK** Technical information and stated dimensions (including in illustrations and drawings) must not be regarded as binding. Design subject to change without notice (in interest of improvement). **FR** Les illustrations techniques et les cotes – y compris sur les schémas et les dessins – sont non contractuelles. Sous réserve d'améliorations de la construction! **IT** Le rappresentazioni tecniche e le indicazioni delle dimensioni – anche nelle figure e nei disegni – non sono vincolanti. Con riserva di miglioramenti di progettazione! **ES** Las descripciones técnicas y los datos dimensionales, inclusive los incluidos en fotos y figuras, son meramente orientativos y no vinculantes. ¡Reservado el derecho a mejoras constructivas! **PT** As descrições técnicas e as indicações de medidas – também em ilustrações e desenhos – não são de natureza imperativa. Salvo melhoramentos de construção! **FI** ekiniset piirroksessa ja mitat – myös kuvissa ja piirroksissa olevat – ovat sitoumuksetta. Oikeus tekniisin parannuksiin pidätetään! **DK** De tekniske fremstillinger og måleangivelser – også i figurer og tegninger – er vejledende. Forbehold for konstruktionsforbedringer! **CZ** Technické znázornění a rozměry – i na obrázcích a výkresech – jsou nezávazné. Konstruktivní změny vyhrazeny! **PL** Prezentacja techniczna i dane wymiarowe – także na rysunkach – są niewiązujące. Zmiany konstrukcyjne zastrzeżone! **RU** Иллюстрации технических деталей и указанные размеры, в том числе на рисунках и чертежах, являются ориентировочными. В конструкции возможны изменения! **TR** Teknik resimler ve ebat bilgileri – fotoğraflar ve çizimler dahil – bağlayıcı değildir. Konstrüksiyon düzeltmeleri saklı tutulmaktadır! **GR** Οι τεχνικές απεικονίσεις και οι διαστάσεις – ακόμα και αυτές που εμφανίζονται στα σχέδια – δεν θεωρούνται δεσμευτικές. Διατηρούμε την επιφύλαξη κατασκευαστικών βελτιώσεων! **JP** 技術データおよび寸法は、改良などによって変更されることがあります。 **CN** 技术图纸和数据 (即使在插图和图纸中) 均不具备法律效力。公司保留进行设计更改的权利!

## cookingAGENT



KESSEBÖHMER  
CLEVER STORAGE

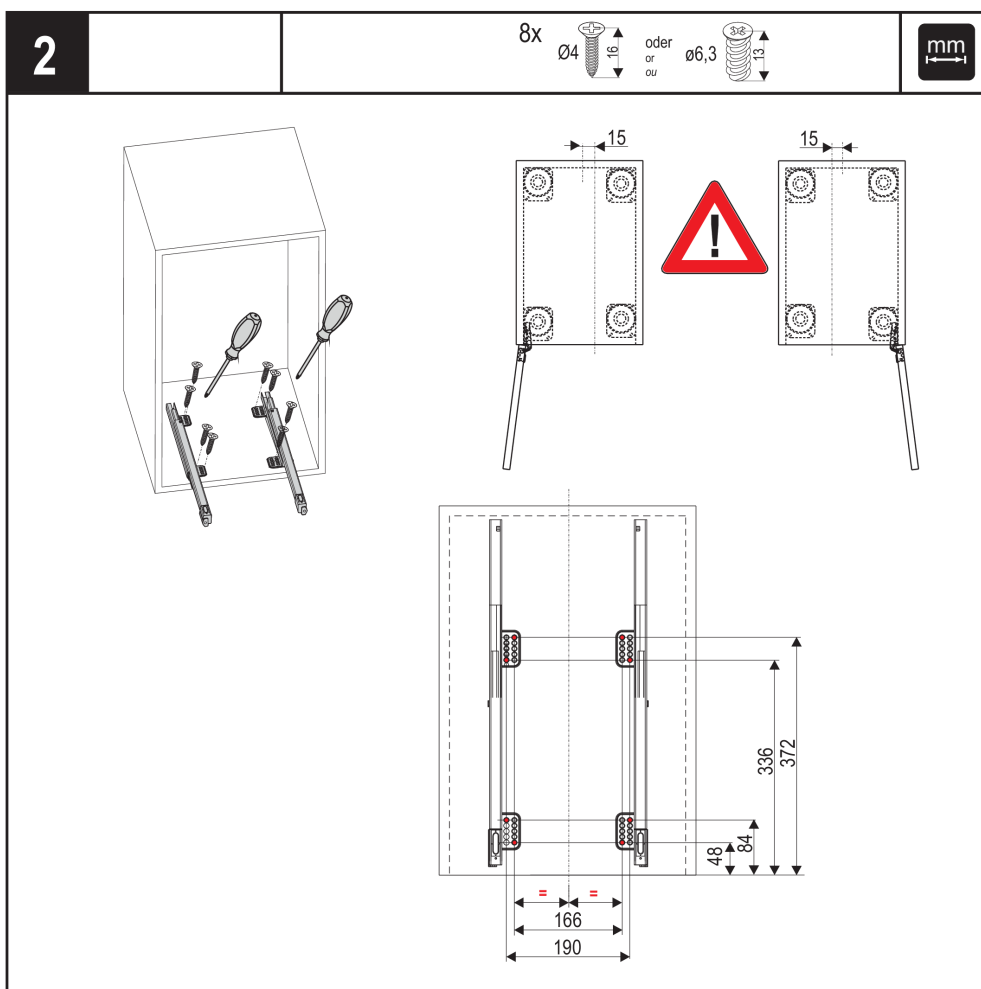
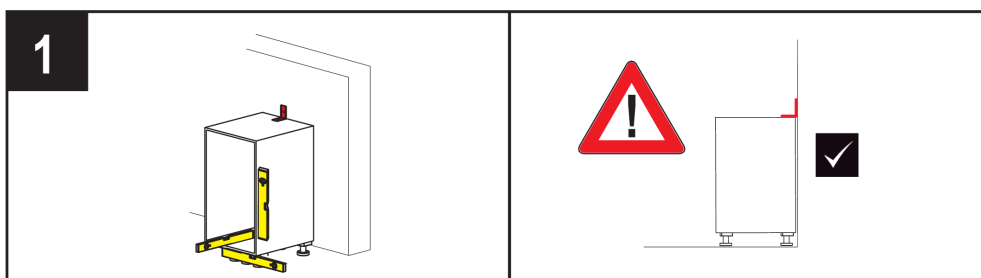

cookingAGENT



KESSEBÖHMER  
CLEVER STORAGE

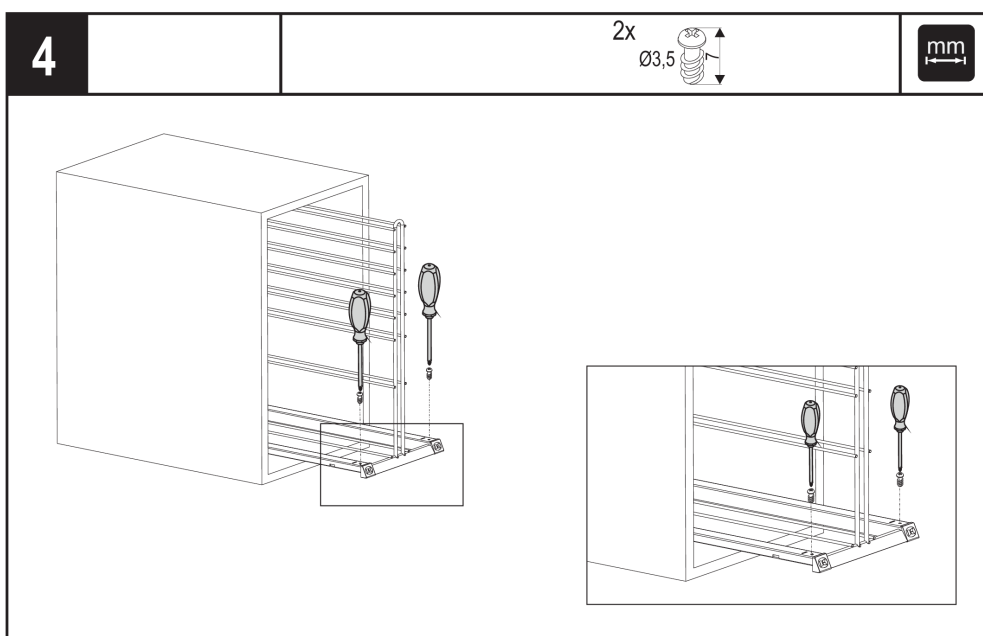
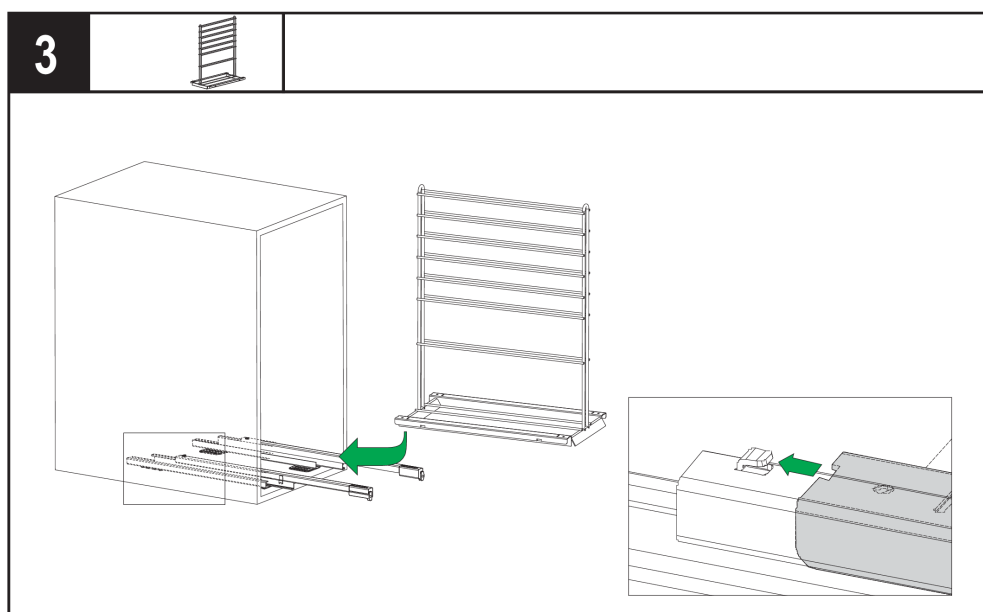

KESSEBÖHMER MA 402598 0000 Rev.: 005-2020-08-31

1 2 3 4